

WPE-D SERIES Hydraulic Pump Electric Drive, Double Action Adjustable Pressure from 350bar to 700bar Flow rate as required

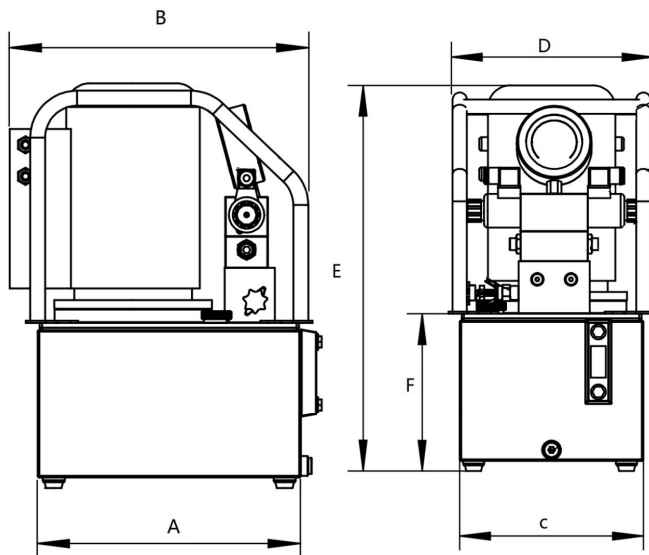

Features:

1. WPE series pump offers 2 stage pressure, and two kinds of flow output exchanges automatically.
2. High quality solenoid offers high stability and durability..
3. Non-carbon brush motorsupply a steady performance and long working life.
4. Smart cooling system allows long time continuous operation.
5. With easy-economical repair parts, the pump can be used for long time with these recycle parts.



MODEL: WPE-1D-6		MODEL: WPE-1D-11	
ELECTRIC PUMP SINGLE ACTION 6L/min flow rate @ 0bar		ELECTRIC PUMP SINGLE ACTION 11L/min flow rate @ 0bar	
specifications		specifications	
For use cylinder type	double-acting	For use cylinder type	double-acting
Motor	110V/220V/380V 50HZ/60HZ 1.5KW 1500RMP	Motor	110V/220V/380V 50HZ/60HZ 1.5KW 1500RMP
Reservoir Capacity	12.7L	Reservoir Capacity	12.7L
Reliable Capacity	8.5L	Reliable Capacity	8.5L
Valve Function	Advance Hold Return	Valve Function	Advance Hold Return
Valve Type	4-way	Valve Type	4-way
Oil delivery @ 0bar	6L/m	Oil delivery @ 0bar	11.2L/m
Oil delivery @ 60bar	1.1L/m	Oil delivery @ 60bar	2.2L/m
Oil delivery @ 350bar	1.1L/m	Oil delivery @ 350bar	2.2L/m
Oil delivery @700bar	1.1L/m	Oil delivery @700bar	2.2L/m
Oil level sight glass	yes	Oil level sight glass	yes
Reservoir drain plug	yes	Reservoir drain plug	yes
power cord length	7.6m	power cord length	7.6m
hand pendant length	7.6m	hand pendant length	7.6m
Max PSI output	700bar	Max PSI output	700bar
exterior pressure adjustment knob	yes	exterior pressure adjustment knob	yes
oil gauge	1000bar	oil gauge	1000bar

WPE-D SERIES DIMENSIONS SHEET (METRIC)

Item No.	A	B	C	D	E	F
	(mm)	(mm)	(mm)	(mm)	(mm)	(mm)
WPE-1D-6	335	397	245	264	482	179
WPE-1D-11	335	397	245	264	515	212